



北京首钢股份有限公司
BEIJING SHOUGANG CO., LTD.

镀锡板 产品手册

TINPLATE PRODUCT MANUAL



北京首钢股份有限公司
Beijing Shougang Co., Ltd.

Chapter 1 Production Line Introduction

第一章 产线简介

1.1 产线特点 Production line characteristics

1.1.1 产线流程紧凑 Compact production process



一罐到底技术 One ladle transfer tech

自主研发高炉—转炉界面“一罐到底”技术；One ladle transfer from BF to BOF self developed technology
为世界大型钢铁企业首家使用，减少铁水运输过程温降。First application in globe steel industry, reducing temperature loss during hot metal transfer



连铸坯热送热装先进工艺 Slab hot delivering & hot charging technology

热送热装率已达到 66% 以上；Hot delivery ratio 66%
热装板坯温度平均为 602 °C，大幅度降低了能源消耗。
Low energy consumption, average charging temperature 602°C



热轧钢卷双排式托盘运输系统 Double row pallet transfer system for hot coils

2250mm 热轧成品钢卷运输采用双排式托盘运输方式，为世界首例；Double row pallet transfer system applied for hot rolled coil transfer in 2250 hot mill, first application worldwide
整个运输过程钢卷不落地，不需要倒运，全自动化操作是现有的各种运输方式中运输功最小、物流运输周期最短的方式。Without temporary landing, secondary hauling and fully automatic control. Minimum power consumption among present transfer solution and minimum logistic cycle time

1.1.2 炼铁系统 Iron making system



5500 m³ 顶燃式热风炉 5500 m³ dome-combustion blast furnace

在 5000m³ 以上级高炉采用顶燃式热风炉，节省投资 15%，占地 10%；Dome-combustion furnace in the level more than 5500m³ BF, 15% saved in investment, 10% saved in area.
采用煤气、空气两级预热，实现了全烧高炉煤气获得 1300°C 高温；Preheated by coal gas and air, 1300°C obtained for BF gas.



高炉全干法除尘技术 BF dust remove with full dry technology

净煤气含尘量 2~3mg/m³ 左右，低于 5mg/m³ 的设计水平；Net gas contains dust 2~3mg/m³, lower than standard 5 mg/m³
年均 TRT 发电量为 48.091kwh/t，发电总量为 4.3067 亿 kwh；Annual TRT electric powre generation 48.091kwh/t, total generation 430.67 million kwh.

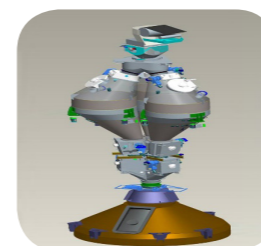

自主设计并罐无料钟炉顶 Self-designed bell-free dome

布料溜槽使用周期达到产铁量 456 万吨；Serving life for distribution chute attained 4.56 million tons
利用主皮带液压马达调速功能，应用矿焦下料模式，实现了大矿批冶炼。hydraulic motor with speed regulation application in main belt and mine&coke loading application, large batch mine melting realized.

1.1.3 炼钢系统 Steel making system



300t 顶底复吹转炉及干法除尘技术 300t converter with top&bottom blowing and dry dusting tech

“全三脱”冶炼条件下实现转炉煤气干法除尘技术，实现废水零排放；Dry dusting technology application for duplex converter process, waste water zero-drainage realized
静电除尘器卸爆控制技术，卸爆率稳定在 0.15% 左右，卸爆控制达到世界先进水平。Pressure relief control tech in electrostatic precipitator, relief ratio has kept in 0.15% around. Relief control tech. has reached the advanced level of the world.

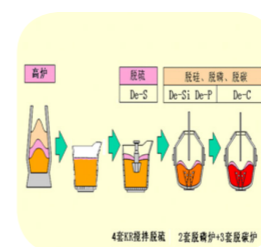

自主创新“全三脱”炼钢工艺 Self developed tech with hot metal pretreatment & duplex converter process

KR 脱磷率稳定在 99% 以上；KR desulfurization more than 99%,
脱磷转炉实现整炉役顶底复吹同步，最高炉龄 13969 炉；Synchronus top&bottom blowing in de-phosphorus converter, maximum service life 13969 heats,

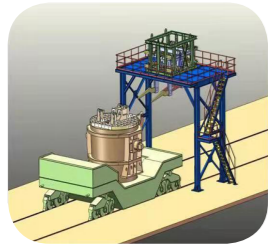

节能降耗钢包加盖技术 Ladle capping tech

降低炼钢转炉出钢温度； Tapping temperature reduced
提高钢包包龄，提高 CAS 罩使用寿命； extend ladle service life, improve CAS cover life time
取消钢包覆盖剂，减少 RH 覆盖剂，节约能源介质和耐材损耗。Prevention from energy and refractory consumption without use of ladle covering powder for ladle and RH.

1.1.4 热轧系统 Hotrolling system



热轧 2250 生产线、1580 生产线优势互补 Complementary advantages of 2250mm and 1580mm line

2250 引进德国 SMSD 公司技术和日本 TMEIC 公司高精度自动化控制技术，最大生产宽度 2130mm，国内最宽热轧生产线之一； 2250mm hot rolling line: imported SMSD tech and TMEIC high-precision automatic control system, maximum strip width 2130mm. One of widest hot mills in China.
1580 是国内自主集成的生产线，最薄生产厚度 1.2mm。 1580mm hot rolling line: thinnest thickness 1.2mm.



20 余项轧制先进技术，达到世界一流水平 More than 20 advanced techniques adopted, attain world first class

热送热装工艺：节能、降耗、实现工序间连续化生产，节约库存资金占用； Hot transfer and charging technology, energy saving, low consumption, continuous production, stock and capital saving
大侧压定宽机、AWC 自动宽度控制、AGC 自动厚度控制、CVCPLUS（连续可变凸度控制）系统、液压活套调节装置确保尺寸、板型精确控制。 side press with high reduction, AWC automatic width control ,AGC automatic gauge control, CVC plus (continuous variable crown control) system, accurate control in width, thickness, profile and flatness , online surface quality inspection system.



高效精确控轧控冷技术，满足多品种生产要求 Controlled rolling and cooling with high efficiency and precise, satisfy diversified product manufacturing

高效精确控轧控冷，满足多相钢、超微细晶粒钢等高强钢的生产； Highly efficient controlled rolling and cooling serve for multi-phase, extra fine grain HSS steel manufacturing.
采用灵活控制的高效节能型层流冷却装置，可进一步提高产品质量。并预留快速冷却装置，实现不同的冷却制度，满足多品种生产要求。 Equipped with highly efficient and energy saving laminar cooling system with flexible control , further improving product quality. Fast cooling prevision to realize different cooling strategy and satisfy diversified product.

1.1.5 冷轧系统 Cold rolling system



国内最薄规格生产能力、最高速度电镀能力 Capability in lightest dimension, fastest electrolytic coating

引进德国 SMS、SIEMENS，日本 TMEIC，法国 Five-Stein 等公司先进工艺设备； Imported advanced equipment and tech. from SMS、SIEMENS Germany, TMEIC Japan, Five-Stein,etc.
具备 0.12mm 极薄规格一次材、二次材生产能力。 Capability in single reduced、double reduced extra thin tin plate with 0.12mm.



国内首创二次冷轧在线轧制技术，效率更高、质量更好 First application in on-line secondary cold rolling tech in China, high efficiency and quality

大压下稳定通板技术，实现炉区、DCR 全高速稳定通板； Stable passing through CAL technology with high reduction, realize stably passing through furnace and DCR mill with high speed.
板形控制技术，一贯制板形、轧制工艺协同控制； Shape control tech, thoroughgoing shape control and rolling process coordination ;
机组自动清洁技术，有效减少表面残留、满足高表面质量要求。 Automatic cleaning tech, reducing residual on strip surface to satisfy HQ surface requirement.



国内首创绿色、环保、低消耗的电镀锡工艺 First green, environment protection low consumption application in tinning process in China.

可溶性阳极 + MSA 电镀系统，有效减少锡泥造成的黑灰。 Soluble anode+ MSA electrolytic coating, reducing tin dust from tin sludge efficiently.
纯感应软熔，消耗更低、表面更好。 Full induction reflow, lower consumption and better surface.
零排放表面处理液循环系统，更低的环境负担。 0 solution drainage circulation system, lower environment burden

1.2 生产流程示意图 Process Diagram

1.2.1 炼钢系统 Steel making system

炼钢系统是一座崭新的低成本、高品质洁净钢生产平台。

Steel making system is a brand new platform for Low cost and high quality clean steel production.

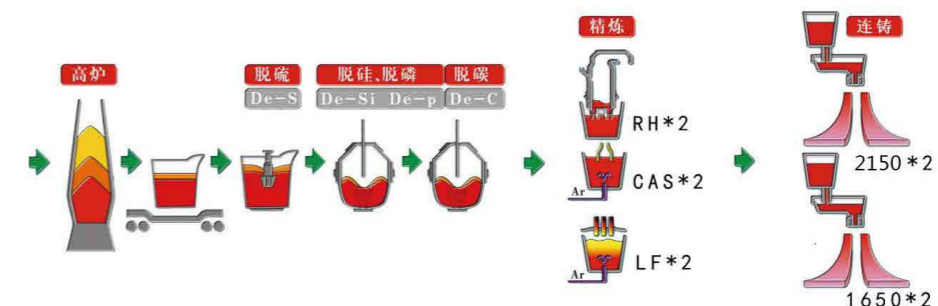

炼钢系统工艺流程图 / Flow Chart illustrating the Steel-making Process

1.2.2 热轧系统 Hot rolling system

首钢京唐拥有 1580mm 和 2250mm 两条热轧生产线，采用了热送热装工艺、工艺润滑技术、大侧压定宽机、自动宽度控制、自动厚度控制、板形控制、控轧控冷以及表面质量在线检测系统等技术。

Shougang Jingtang Steel has two Hot Rolling lines, one is 1580mm Hot Rolling line, and the other is 2250mm. The system adopts hot charging technology, processing lubrication technology, side press with high reduction, automatic width control, automatic thickness control, strip flatness control, controlled rolling & cooling, as well as the online surface quality inspection system.

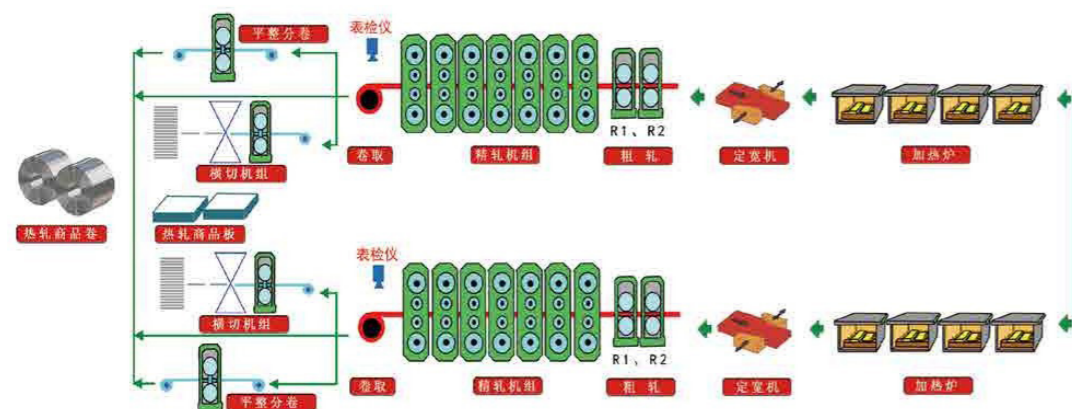

热轧生产线工艺流程图 / Flow Chart illustrating the Hot Rolling Process

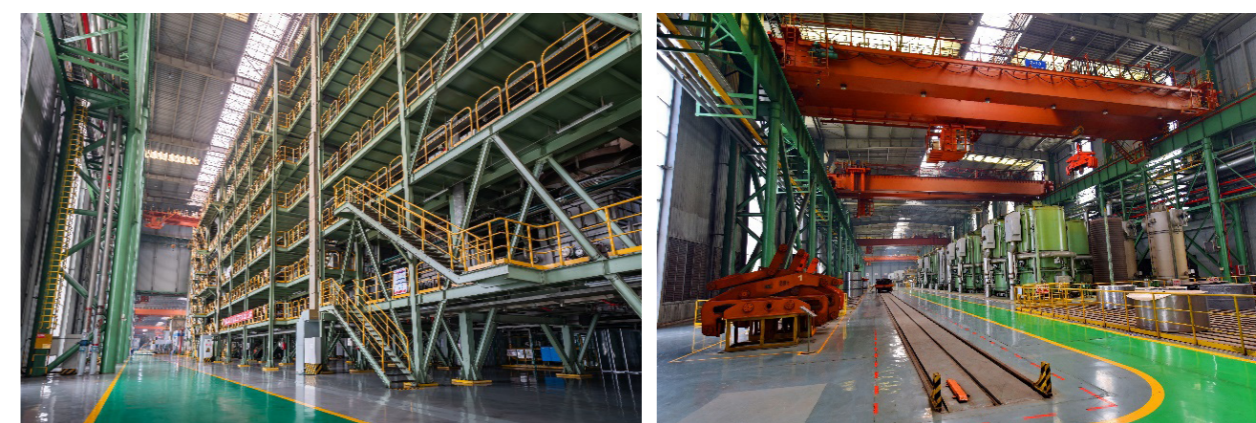

1.2.3 冷轧系统 Cold rolling system

首钢京唐 1420 冷轧厂配备有 1 条酸洗轧机联合机组、1 条连续退火机组、1 条罩式退火机组、2 条电镀锡机组、2 条横切机组。首钢凯西钢铁有限公司马口铁分厂配备有 2 条电镀铬线、1 条横切机组。主要产品为高级包装用电镀锡板，产品规格范围为厚度：0.12-0.55mm；宽度：700-1280mm。

The 1420 cold rolling plant is equipped with one PL-TCM, one CAL, one BAL, two ETLs, two DCRs, two CCLs. The main production is high-level tinplate for packing. The standard range of thickness is from 0.12mm to 0.55mm; and width is from 700mm to 1280mm.

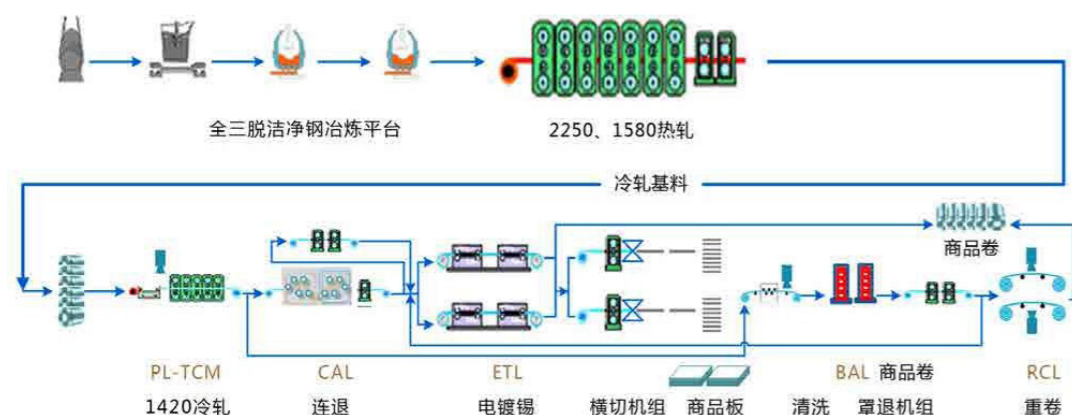

注 Note:

镀锡板、镀铬板在全工序制造流程中严格遵守“一贯制”质量管理的要求，因此保证了优异的耐蚀性和均匀的材料性能满足制罐材料要求。

Tinplate and TFS products are manufactured under strict quality control all through the manufacturing process to provide the excellent corrosion resistance and uniform material properties required of can-making materials.

Chapter 2 Products Introduction

第二章 产品介绍

镀锡板在钢板表面电镀一层金属锡，镀铬板在带钢表面经电镀形成金属铬层和氧化铬层，是一种生产技术复杂、技术性强、制造流程长、质量要求高且制造难度大的产品。具有非常漂亮的金属光泽，优异的耐性蚀和涂饰性。

首钢拥有 65 万吨马口铁产品产能。拥有先进的工艺装备、丰富的生产管理经验和良好的服务以及一流的产品研发队伍，具备从冶炼、热轧、冷轧到涂镀全流程的制造能力。产品面向全球销售，广泛应用于食品、饮料和工业品包装等领域。

Tinplate is a thin steel sheet coated by tin, while TFS is an electrolytic chrome plated steel consisting of a thin layer of chromium and a layer of chromium oxide deposited on the steel base, with complex production technology, high technology, long manufacturing process, high quality requirement and difficult manufacturing. Tinplate have a beautiful metallic luster as well as excellent properties in corrosion resistance and paintability.

A company of Shougang project design annual output of 650,000 tons of tin mill products. Shougang have advanced technical equipments, first class inspection devices, skilled operators, excellent services and outstanding product development personnel. It possesses integrated process lines including ironmaking, steelmaking, hot rolling, cold rolling and coating. Shougang's tin mill products are widely sold and used throughout the world in application of packaging of food, beverage and industrial goods.

2.1 产品系列 Product series

2.1.1 产品标准 Product standard

1. 镀锡板 ETP

电镀锡板执行首钢订货标准 Q/SGZGS 0350-2019，此标准非等效采用了 JIS G3303: 2017、DIN EN 10202: 2001、EN 10203。

ETP orders are placed with shougang in accordance with Q/SGZGS 0350-2019 standard which uses in a non-equivalent to JIS G 3303:2017, DIN EN 10202:2001, EN 10203 standards.

2. 镀铬板 TFS

电镀铬板执行首钢订货标准 Q/SGZGS 0370-2018，此标准非等效采用了 JIS G3315: 2017、DIN EN 10202: 2001、EN 10203。

TFS orders are placed with shougang in accordance with Q/SGZGS 0370-2018 standard which uses in a non-equivalent to JIS G 3315:2017, DIN EN 10202:2001, EN 10203 standards.



2.1.2 镀锡产品 Tin Mill Products

镀锡板 Tinplate Products	一次冷轧镀锡板 (SR ETP)
	二次冷轧镀锡板 (DR ETP)
镀铬板 TFS Products	一次冷轧镀铬板 (SR TFS)
	二次冷轧镀铬板 (DR TFS)

注：镀锡板包括 K-板、DI 材、低锡铁、低铬铁等。
Note: Tinplate includes K-Tinplate, DI-Tinplate, Low-Tinplate, L-Cr Tinplate.



2.2 产品特性 Product properties

2.2.1 镀锡板特性 Features of tinplate products

优异的耐蚀性 Excellent Corrosion Resistance	选择合适的镀层厚度可以满足不同内容物的耐蚀性要求 By selecting a proper coating weight, appropriate corrosion resistance is obtained against container contents.
优异的涂饰性 Excellent Paintability & Printability	可用各种涂料和油墨进行印刷 Printing is beautifully finished using various lacquers and inks.
优异的焊接性 Excellent Solderability & Weldability	可用焊接（包括钎焊）制造各式各样的罐头 TIN PLATE is widely used for making various types of cans by soldering or welding.
优异的加工性和强度 Excellent Formability & Strength	选择合适的调质度等级可以满足加工要求以及成型后的强度 By selecting a proper temper grade, appropriate formability is obtained for various applications as well as the required strength after forming.
亮丽的外观 Beautiful Appearance	镀锡板表面金属光泽亮丽选择不同表面状态的基板得到不同表面粗糙度的产品 Electrolytic ETP is characterized by its beautiful metallic luster. Products with various kinds of surface roughness are produced by selecting the surface finish of the substrate steel sheet.

2.2.2 镀锡板特性 Features of TFS products

优异的涂料附着力 Excellent paint adhesion	涂料附着力远远超过镀锡板，可以用于制造 DRD 罐和胶接罐 TFS has excellent paint adhesion properties that far surpass those of ETP, allowing its use for making DRD cans and adhesive bonded cans.
优异的耐热变性 Excellent heat resistance	耐高温烘烤，不变色，材料性能不劣化 High-temperature baking causes neither discoloration nor deterioration in material properties.
优异的抗硫化性 Excellent resistance to Sulphur Blackening	金属铬层有良好的抗硫化物性能，适用于富含蛋白质食物如鱼的听头 The metallic chromium in TFS has excellent sulphide resistance property when canning protein-rich foodstuff such as fish. TFS compensates for the expensive sulphur resistant lacquer.
优异的耐丝状腐蚀性 Excellent filiform rust resistance	漆膜下的耐丝状腐蚀能力优异 TFS has a excellent under film corrosion resistance.
优异的耐碱性 Excellent alkali resistance	镀铬层是非两性材料，更适用于碱性内容物如清洗剂、颜料分散剂的包装 The coating in TFS is not amphoteric. Alkaline products such as detergents and dispersion colours can be packed in TFS with advantage.

2.2.3 镀锡板食品罐的优点 Advantages of tinplate cans in food packaging

卫生 Hygienic	提供优异且无毒的屏障保护食品，保持水分，不受污染，保持食品风味。 Provide excellent and non-toxic barrier properties to protect food products from impurities, bacteria, moisture, light, and odours.
安全 Safe	轻质和高强度的食品罐便于运输和储存。 Low weight and high strength make food cans easy to ship and store.
环保 Eco-friendly	可 100% 回收，比铝的成本低。 Offer 100% recyclability; and significant cost benefits compared with aluminum.

2.2.4 镀锡 K- 板耐蚀能力 K-Tinplate' s resistance to corrosion

酸浸时滞值 PLV Pickling Lag Value	铁溶出值 ISV Iron Solution Value	锡晶粒度 TCS Tin Crystallite Size	合金 - 锡电偶合 ATC Alloy-Tin Couple
≤ 10 Sec	≤ 20µg	≤ 9 级	≤ 0.12µA/cm ²

注：差厚镀锡板检测厚镀层板面的性能。
Note: If different coating tinplate, the side of higher coating weight was tested.

2.2.5 镀锡产品机械性能 Mechanical properties of tin mill products

调质度代号 Temper Grade	硬度 Hardness		屈服强度 Yield Strength/MPa
	目标值 Target Value	范围 Range	
T-1	49	49±3	
T-1.5	51	51±3	
T-2	53	53±3	
T-2.5	55	55±3	
T-3	57	57±3	
T-3.5	59	59±3	
T-4	61	61±3	
T-4.5	63	63±3	
T-5	65	65±3	
DR-7	69	69±4	480
DR-7M	71	71±4	520
DR-8	72	72±4	550
DR-8M	73	73±4	580
DR-9	75	75±4	620
DR-9M	76	76±4	660
DR-10	79	79±4	690

注：使用 DR 板时必须保持罐身成圆方向与板材的轧制方向一致。
Note: Making cans with DR materials, please pay a special attention to the rolling direction.

2.3 产品用途 Applications of tinplate

2.3.1 消费品、工业品的包装 Consumer packaging and Industrial packaging

镀锡板 Tinplate	主要用于食品、饮料等产品包装，也用于汽油、油脂、颜料、抛光剂、喷雾剂等化学品的产品包装。包括盖子、喷嘴和罐身 ETP is primarily used for packaging foodstuffs and beverages, but it is also used in containers for oils, grease, paints, polishes, chemicals and many other products. Aerosol containers and caps and closures are also made from ETP
镀铬板 TFS	主要用作罐头顶盖，旋开盖、凸盖、易拉盖、浅冲罐 TFS are most frequently used for can tops, screw and lug caps, snap and press-on closures and shallow-drawn food cans.

2.3.2 其他用途 Miscellaneous

电子方面 In Electronics	电极、电缆带、电磁屏幕罩壳等 Electrodes, Cable tape, Magnetic screen covers, etc.
工程方面 In Engineering	汽车滤油器、汽车空滤、垫片等 Automotive oil filters, Automotive air filters, Gaskets, etc.
建筑方面 In Construction	气体流量计内部件、热交换器、厨具、货架等 Gas meter internal components, Heat exchangers, cookware, shelving, etc.

2.3.3 特色产品 Feature products

1. 高速制罐饮料罐专用镀锡板 Tinplate for beverage can of high speed can making

典型应用：红牛、露露、旺仔牛奶、六个核桃等饮料罐用铁。

Typical application: Red Bull, LuLu Drink, Want Want Children' Milk, Six Walnuts, and other tinplate drink cans.

典型牌号：MR T-4 CA、MR T-5 CA

Typical grade: MR T-4 CA、MR T-5 CA

关键技术：基于高速退火性能稳定控制技术、电镀工艺与涂料匹配技术、高表面质量全流程控制技术。

Key technology: Control technology based on high speed continuous annealing with stable and reliable performance,electroplating process match the painting process,the control technology in guarantee of high surface quality through the whole procedures.

技术指标 表面质量满足透铁印刷技术要求、性能均匀性满足 700 罐以上/分钟高速制罐、附着力、抗硫性能达到 1 级。

Technology index: The surface quality reaches the design requirements of printing process,stable performance reach the requirements of high speed can making lines which produce more than 700 cans/min , adhesive force and sulfur resistance reach the design requirements of class1.



2. 八宝粥专用镀锡板 Tinplate for eight-treasure porridge

典型应用：银鹭、达利园、娃哈哈等八宝粥、绿豆汤等粥、汤类产品。

Typical application: eight-treasure porridge ,mung bean soup products include Yinlu,Darley garden,Wahaha.

典型牌号：MR T-4 CA、MR T-5 CA

Typical grade: MR T-4 CA、MR T-5 CA

关键技术：粗糙度稳定控制技术、抗硫附着力协同控制电镀技术。
Key technology: Control technology of stable rough surface performance, Control technology of adhesive force and sulfur resistance.

技术指标：附着力、抗硫性能 1 级，满足高温蒸煮杀菌要求。

Technology index: Adhesive force and sulfur resistance reach the design requirements of class1、Products reach the requirement of high temperature sterilization.



3. 高耐蚀性食品罐专用镀锡板 Tinplate for corrosion resistance food cans 典型应用：水果罐、番茄罐、蘑菇罐等。

Typical application: fruit cans,tomato cans,mushroom cans.

典型牌号：MR T-4 CA、MR T-5 CA、MR DR-7M CA

Typical grade: MR T-4 CA、MR T-5 CA、MR DR-7M CA

关键技术：镀前表面清洁度控制技术、高锡量精准电镀控制技术、低孔隙率纯感应软熔控制技术。

Key technology: Control technology of the cleanliness of surface before electroplating, Accurate control technology of tinplate with high tin coating weights, Control technology of less porosity induction reflow system.

技术指标：ATC ≤ 0.12μA/c、ISV ≤ 20μg、PLV ≤ 10s、TCS ≤ 9 级。

Technology index: ATC ≤ 0.12μA/cm、ISV ≤ 20μg、PLV ≤ 10s、TCS ≤ 9 class.



4. 奶粉罐专用镀锡板 Tinplate for Infant formula

典型应用：奶粉罐罐身、底盖、子母盖、易撕盖。

Typical application: can body, bottom cap, child-mother cap, easy tear cover.

典型牌号：MR T-3 BA、MR T-4 CA

Typical grade: MR T-3 BA、MR T-4 CA

关键技术：粗石纹表面粗糙度控制技术、湿平整表面纹理控制技术、表面黑灰控制技术。

Key technology: Control technology of roughness of rough stone surface, Control technology of surface texture of wet skin pass, Control technology of dust pick-up.

技术指标：黑灰优于2级、涂印无花架印。

Technology index: Tin dust build-up better than class 2, free of flower frame printing when printing.



7. 三片罐专用DR材镀锡板 DR Tinplate for three-piece can

典型应用：番茄罐、蔬菜罐。

Typical application: tomato cans, canned vegetables.

典型牌号：MR DR-7M CA、MR DR-8 CA、MR DR-8 BA

Typical grade: MR DR-7M CA、MR DR-8 CA、MR DR-8 BA

关键技术：阶梯式高速退火控制技术、在线二次轧制稳定控制技术。

Key technology: Control technology of stepped high speed annealing process, Stable control technology of on line double reduce process.

技术指标：硬度波动±5、强度波动±50Mpa，满足滚筋、翻边成形要求。

Technology index Hardness tolerances±5、Proof/Tensile strength tolerances±50MPa、Mechanical properties meet the requirements of rolling and wrinkling process.



5. 易开盖 (E0E) 专用镀锡板 Tinplate for easy open ends

典型应用：各类食品罐易开盖。

Typical application: food cans.

典型牌号：MR T-4 CA、MR T-5 CA

Typical grade: MR T-4 CA、MR T-5 CA

关键技术：厚度边缘降控制技术、高成形性控制技术、电镀工艺与涂料匹配技术。

Key technology: Control technology of the variance between centre and mill-trimmed edge on thickness, Control technology of high formation, Control technology of electroplating process that match the printing process.

技术指标：硬度波动±3、横向延伸率≥5%、抗硫、附着力性能1级。

Technology index: Hardness tolerances±3、Transverse elongation ≥5%、Adhesive force and sulfur resistance reach class1.



8. 旋开盖专用DR材镀锡板 Tinplate for unscrew cap

典型应用：老干妈、海天酱等旋开盖。

Typical application: Laoganma, Haitian soybean sauce.

典型牌号：MR DR-7M CA、MR DR-8 CA、MRDR-9 CA、MR DR-8 BA

Typical grade: MR DR-7M CA、MR DR-8 CA、MRDR-9 CA、MR DR-8 BA

关键技术：N强化控制技术、低制耳控制技术、在线二次轧制稳定控制技术。

Key technology Control technology of N strengthening processes, Control technology of lower earing, Control technology of on line double reduce process.

技术指标：硬度波动±5、强度波动±50Mpa，满足滚筋、翻边成形要求。

Technology index Hardness tolerances±5、Proof/Tensile strength tolerances±50MPa、Mechanical properties meet the requirements of rolling and wrinkling process.



6. 两片罐专用镀锡 / 铬板 Tinplate/ECCS for two-piece can

典型应用：鱼罐头、番茄罐等。

Typical application: canned fish, tomato cans.

典型牌号：MR T-2.5 BA、MR T-3 BA、D T-3 CA DI、MR DR-8 CA

Typical grade: MR T-2.5 BA、MR T-3 BA、D T-3 CA DI、MR DR-8 CA

关键技术：高洁净度炼钢控制技术、热轧温度精准控制技术、低制耳控制技术。

Key technology: Control technology of high cleanliness of slab, Control technology of accurate temperature of the hot rolling process, Control technology of lower earing.

技术指标：塑性满足冲压成形要求、金属流动与彩印图案相匹配、各项异性小满足修边要求。

Technology index: Good shaping performance meets the stamping process, Metal flow performance meets the printing process, Less anisotropy to meet trimming process.



9. 喷雾罐阀门专用镀锡板 Special tinplate for aerosole valve

典型应用：喷嘴阀门。

Typical application: nozzle valve.

典型牌号：MR T-2 BA Typical grade: MR T-2 BA

关键技术：厚度边缘降控制技术、通卷性能稳定性控制技术、双面高锡表面抗划伤控制技术。

Key technology: Control technology for edge drop, control technology for stable property in whole coil, Control technology of the scratch resistance of two-sides high coatings tinplate.

技术指标：厚度波动控制在5μm以内，硬度控制波动±3，满足抗压和成形要求。Technology index

Thickness tolerances±5μm, Hardness tolerances±3, Good compression resistance and compactibility.



10、电子产品专用镀锡板 Tinplate for electronic products

典型应用：电子零件等。

Typical application: electronic products.

典型牌号：MR T-2.5 BA、MR T-3 BA

Typical grade: MR T-2.5 BA、MR T-3 BA

关键技术：厚度精确控制技术、表面黑灰控制技术。Key technology

Control technology of thickness accuracy, Control technology of tin dust build-up.

技术指标：黑灰优于 2 级、不平度 $\leq 2\text{mm}$ 、硬度波动 ± 3 。

Technology index: Tin dust build-up reach class 2,maximum fullness 2mm、Hardness tolerances ± 3 .



特殊说明：

首钢具备 EVI 服务能力，产品具备 0.12mm 厚度、0.5g/m² 镀层的生产能力；采用 MSA 环保镀液，特殊的除铅工艺技术，具备低铅镀锡板的供货能力，满足国内及欧美食品安全要求；结合欧盟环保要求，装备无铬钝化实验及生产设备，具体无铬钝化实验及生产能力。

Addition:

Shougang serves products with EVI, and the production capacity reaches the level that 0.12mm of thickness and 0.5g/m² coating of tinplates; as well as the technology of environmental solution MSA and eliminating the harmful element Pb are applied. Our products already reaches the requirements of domestic and international food safety standard. Recently we are conducting some experiments about free chromium passivation for producing in bulk of free chromium passivation products.

2.4 供货规格 Available specifications and size

2.4.1 钢种 Steel grade

钢种 Steel grade	特性 Characteristics
MR	非金属夹杂物含量与 L 类钢相近残余元素含量的限制没有 L 类钢严格具有良好的耐蚀性适用于大多数用途。Similar content in non-metal inclusion and less limitation in residual element compared with L type, excellent corrosion resistance, widely used in general applications.
L	非金属夹杂物以及 Cu、Ni、Cr、Mo 等残余元素含量低用于对耐蚀性有较高要求的用途。Low non-metal inclusion and residual elements such as Cu, Ni, Co, and Mo, used for higher corrosion resistance application.
D	用于深冲压或限制滑移线产生的用途。Used for deep drawing or Lueder's lines limitation.

注：若需要特殊钢种，请联系我们。
Note: With regard to steel types other than those listed above, please consult us.

2.4.2 尺寸规格 Available sizes

基板类型 Black Plate	公称厚度 Normal Thickness	公称宽度 Normal Width	公称长度 (钢板) Normal Length(sheet)	内径 (钢卷) Inside Diameter(coil)
一次冷轧 Single reduce	0.15 ~ 0.55mm	700 ~ 1250mm	500 ~ 1200mm	420mm/508mm
二次冷轧 Double reduce	0.12 ~ 0.35mm			

2.4.3 调质度 Temper grade

基板类型 Black Plate	罩式退火 Batch Annealing	连续退火 Continuous Annealing
一次冷轧 Single reduce	T-1, T-1.5, T-2, T-2.5, T-3, T-3.5, T-4, T-5	T-2, T-2.5, T-3, T-3.5, T-4, T-4.5, T-5
二次冷轧 Double reduce	DR-7, DR-7M, DR-8, DR-8M	DR-7, DR-7M, DR-8, DR-8M, DR-9, DR-9M

注：
提供两种退火方式，罩式退火 BA 或者连续退火 CA，如果为连续退火，调质度表示为 T-4CA。
Note:
There are two types of annealing: batch annealing (BA) and continuous annealing(CA). When continuous annealing is designated, the symbol of "CA" is added after the temper grade symbol such as "T-4CA" .

2.4.4 镀层厚度 Coating weight

(1) 镀锡板 ETP

镀层形式 Coating form	镀锡量代号 Coating Weight Code	公称镀锡量 Nominal Coating Weight(g/m ²)	最小平均镀锡量 Minimum average Coating Weight (g/m ²)
等厚镀锡 Equally Coated	1.1/1.1	1.1/1.1	0.9/0.9
	2.2/2.2	2.2/2.2	1.8/1.8
	2.8/2.8	2.8/2.8	2.45/2.45
	5.6/5.6	5.6/5.6	5.05/5.05
	8.4/8.4	8.4/8.4	7.55/7.55
	11.2/11.2	11.2/11.2	10.1/10.1
差厚镀锡 Differentially Coated	2.8/1.1	2.8/1.1	2.45/0.9
	5.6/1.1	5.6/1.1	5.05/0.9
	5.6/2.8	5.6/2.8	5.05/2.45
	8.4/2.8	8.4/2.8	7.55/2.45
	8.4/5.6	8.4/5.6	7.55/5.05
	11.2/2.8	11.2/2.8	10.1/2.45
	11.2/5.6	11.2/5.6	10.1/5.05
11.2/8.4	11.2/8.4	10.1/7.55	

注：
(1) 应该按照产品最终用途选择镀锡层厚度：锡层厚的用于需要高耐蚀性或者素板的场合，锡层薄的用于耐蚀性要求不高或者印涂之后使用的场合。
(2) K 板和 J 板镀锡量通常不低于 2.8/8.4g/m²。Note:
(1) The tin coating weight is determined in accordance with specific end use applications. Tinplate with a heavy coating weight is used for making cans that require a high corrosion resistance or bare plate. Tinplate with a light coating weight is used for the situation low requirement in corrosion resistance or post painting.
(2) The tin coating weight of K-tinplate and J-tinplate is usually not less than 2.8/8.4g/m².

(2) 镀铬板 TFS

金属铬层 (每面) Metallic Chromium Layer(one side)		氧化物铬层 (每面) Chromium Oxide Layer(one side)	
最小平均重量 Minimum Average Coating Weight Coating Weight	最大平均重量 Maximum Average Coating Weigh	最小平均重量 Minimum Average Coating Weight	最大平均重量 Maximum Average Coating Weigh
50 mg/m ²	140 mg/m ²	5 mg/m ²	35 mg/m ²

2.4.5 表面状态 Surface finishes

原板类型 Black Plate	代号 Code	表面状态 Surface finishes	特征 Features
一次冷轧 Single reduce	B	光亮表面 Bright surface	在具有极细磨石花纹的光滑表面的原板上镀锡后进行锡的软熔处理得到的有光泽的表面。Luster surface obtained by reflow treatment after tin coating for base plate with extremely fine stone figures.
	R R2	石纹表面 Stone surface	在具有一定方向性的磨石花纹为特征的原板上镀锡后进行锡的软熔处理得到的有光泽的表面，R2表面粗糙度略高于R表面。Luster surface obtained by reflow treatment after tin coating for base plate featuring with certain oriented stone figures. Roughness of R2 is higher than R.
	S	银色表面 Silver surface	在具有粗糙无光泽表面的原板上镀锡后进行锡的软熔处理得到的有光泽的表面。Luster surface obtained by reflow treatment after tin coating for base plate featuring with rough and matt surface.
	M	无光表面 Matte surface	在具有一般无光泽表面的原板上镀锡后不进行锡的软熔处理的无光表面。Matt surface without reflowing treatment after tin coating for base plate with matt surface.
二次冷轧 Double reduce	R	石纹表面 Stone surface	在具有一定方向性的磨石花纹为特征的原板上镀锡后进行锡的软熔处理得到的有光泽的表面。Luster surface obtained by reflow treatment after tin coating for base plate with certain oriented stone figures.
	M	无光表面 Matte surface	在具有一般无光泽表面的原板上镀锡后不进行锡的软熔处理的无光表面。Matt surface of general matt raw material strip without reflowing treatment.

2.4.6 涂油 Oiling

无特殊要求,表面涂 DOS-A 油,且采用静电涂油方式。

If no engagement, tinplate is electro statically oiled with DOS-A.

2.4.7 铅含量 Lead content

镀层铅含量 ≤ 100ppm。

Lead content in tin coating is ≤ 100ppm.

2.4.8 无铬钝产品 Chromium free product

无铬钝化产品附着力 1 级,抗硫 ≤ 2 级。

Chromium free product adhesion class 1, sulfur resistance level ≤ 2.

Chapter 3 Quality Assurance System

第三章 质量保障

首钢京唐在引进国外先进技术装备的同时,为了使首钢京唐产品在国内和国际市场上更具竞争力,满足用户的需要,首钢京唐在借鉴母公司管理经验的基础上,不断完善一贯制质量管理和努力提高产品质量。

通过贯彻实施 ISO9001 和 IATF16949、ISO22000 标准,使首钢京唐质量体系建设和运行不断进入更深层次,质量方针和目标得到深入贯彻和实施,持续改进、缺陷预防,减少变差和浪费能力大大提高。实践证明,一贯质量管理较好地适应了首钢京唐这样的现代化钢铁企业,体现了集中、一贯、高效、优化的特点,实现了质量管理由中间向两头延伸的全过程的整体优化。首钢京唐在自己的质量管理实践中,不断吸收世界先进的质量管理理念和方法,与时俱进,进一步充实和丰富了一贯质量管理的内容。



In the meantime of importing advanced technology and equipment from abroad, Shougang Jingtang continuously improve whole process quality management and product quality with reference of mother company's management in order to have more competitive capacity in domestic and global market for SGJT product and meet customers' requirement.

With the implementation of ISO9001, IATF16049 and ISO22000 standards, the establishment and operation of Shougang Jingtang's QC system kept progressing towards deeper level, quality guideline and goals are implemented and put into operation, improvement is keeping continuously, defects are prevented, fluctuation and waste control capability was increased by a large scale. It was proved by practice that whole process quality management is more suitable for modern steel enterprise like SGJT, which reflects the characteristic of integrating, consistency, high efficiency and optimization, realize full QC optimization in whole process extending from the middle to both ends. SGJT is keeping absorb advanced QA management philosophy and method in the world, catch the pace of times, gets further progress in enriching consistent QC content.



镀锡板主要检测设备 Main testing equipment of tinplate



中国合格评定国家认可委员会实验室认可证书
Physical and Chemical Testing Laboratory Accreditation



产线检验能力

产品质量检验分别在原料分析中心、冶炼分析中心、轧钢测试中心、镀锡薄板实验室完成，具有完整的物理实验室、化学实验室、油质实验室、金相实验室、低倍实验室。从原料进厂、生产过程到产品出厂，都经过严格检验，全过程实现了自动化和信息化，为生产高端精品板材产品提供了可靠保证。

Quality inspection capacity for production lines

The quality inspection is fulfilled in raw material analysis center, me analysis center ,steel rolling testing center and Tin plate Laboratory. There is a complete set of experiment labs, including physics labs, chemical labs, oil quality labs, metallographic labs and low-magnification microscopic labs. Whole process is strictly inspected from the raw material entry, manufacturing process to the final product delivery, automation and informatization has realized in each process, which provides reliable assurance for manufacturing of top level and high quality strip product.

镀锡薄板实验室

提升首钢镀锡板的研发能力，并能够与客户形成更紧密的合作关系，为首钢镀锡板创造效益、为客户创造效益。

Tin plate laboratory

Improve tin plate developing capability for Shou Steel, enable to establish tighter cooperation relationship with customers to create profit for Shou Steel in tin plate production and profit for customers.

创新中心

组织团队优化生产工序中的关键点、解决频繁发生的质量问题。

Innovation center

Organize team to optimize key factor in manufacturing process and solve frequently occurred quality problem.

共建实验室

与用户在“优势互补、资源共享、互利互惠、发展共赢”的原则下，建立战略合作关系，利用各自技术和资源优势实现资源共享，促进双方共赢和共同发展。

Joint laboratory

Establish strategic cooperation relationship with customers base on the principle “complementary advantages, resource sharing, mutually beneficial and reciprocal, Develop a win- win situation”, realize resource shearing with full use of each advantage in technology and resource, promote both benefit and common development.

合作科研 Science Research Cooperation

与北京科技大学、哈尔滨工业大学、东北大学等在镀锡薄板相关领域具备强大科研实力的高校深度合作，充分利用高校优质的人才资源和先进研发设备，共同进行新产品、新工艺的开发，以及生产和应用过程的机理研究。利用高校资源培养自己的高素质人才队伍，提高团队的科研能力。

Deep cooperation with University of Science & Technology Beijing, Harbin Institute of Technology, Northeastern University, etc. fully using excellent human resource in university and advanced R&D facility to commonly work at new product development, new technology development and mechanism research in manufacturing and product application, to improve team R&D capability.

实验室检测能力 Laboratory testing ability

序号 No.	检测能力 testing ability	检测项目 testing item	设备名称 Device name
1	物理性能 Physical properties	洛氏硬度 Rockwell hardness	洛氏硬度计 Hardness tester
2		表面粗糙度、峰值数 Surface roughness, peak number	台式粗糙度仪 Fixed roughness tester
3			手持式粗糙度仪 Portable roughness tester
4		拉伸试验 Tensile test	拉伸试验机 Tensile tester
5	表面结构 Surface structure	镀锡量 Tin coating mass	X 荧光光谱仪 X fluorescent spectrometer
6		镀锡量、合金层、钝化膜、氧化膜 Alloy mass, alloy layer, passivation film, oxidation film	镀锡板多功能测量仪 Multi function tester for tin plate
7		涂油量 Oiling mass	椭圆仪 Ellipsometer
8			亲水平衡 Hydrophile balance
9	尺寸、板型 Size, plate type	边浪 Edge wave	薄板不平度测量仪 flatness detecting meter for light plate
10		翘曲 Bow	翘曲测量装置 Bow measuring device
11		直角度 Squareness	直角度测量仪 Squareness tester
12		宽度、长度、对角线差 Width, length, diagonal difference	宽度测量仪 Width measuring instrument
13	成型性能 Molding properties	杯突实验 Cupping test	杯突试验机 Cupping tester
14		起棱试验 Prism test	起棱试验机 Prism test machine
15		制耳 Earing	制耳率测试仪 Earing simulation
16		抗弯曲力 Anti bending force	抗弯曲力测试仪 Anti bending force tester
17		折弯成型 Bending forming	滑度仪 9505A Skid meter 9505A
18		焊接性能 Welding performance	高频焊机 High frequency welding machine
19	耐蚀性 Corrosion resistance	耐蚀性 Corrosion resistance	电化学工作站 Electrochemical workstation
20		湿热腐蚀性能 Hot and humid corrosion resistance	湿热试验箱 Damp heat test box
21		加速腐蚀 Accelerated corrosion	盐雾试验箱 Salt mist test box
22		货架寿命研究 Research on shelf life	恒温培养箱 Incubator
23		ATC	ATC 装置 ATC device
24		PLV	PLV 自制装置 PLV Homemade device
25		ISV	ISV 自制装置 ISV Homemade device

实验室检测能力 Laboratory testing ability

序号 No.	检测能力 testing ability	检测项目 testing item	设备名称 Device name	
26		TCS	TCS 自制装置 TCS Homemade device	
27	涂饰性能 Coating properties	钢板表面接触角测试 Surface contact angle test of steel plate	光学接触角 Optical contact angle	
28		抗硫、抗酸、耐蒸煮 Sulphur resistant, acid resistant and steaming resistance	高压灭菌蒸锅 Autoclave steamer	
29		附着力 Adhesion	漆膜附着力试验仪 Lacquer adhesion tester	
30		附着力 Adhesion	划格板 Paddle plate	
31		漆膜附着力 Adhesion of paint film	管式漆膜冲击器 BGD 304 Tubular lacquer impactor	
32		漆膜硬度 Film Hardness	铅笔硬度计 BGD 506 Pencil hardness tester	
33		涂膜完整性 Film integrity	缺陷电流仪 Digital enamel rater	
34		涂膜厚度 Film thickness	涂膜厚度测定仪 Coating thickness gauge	
35		电镀工艺模拟 Simulation of electroplating process	电镀工艺模拟 Processing simulation	全自动高速镀锡模拟装置 Automatic high-speed tin plating simulator
36			工艺模拟研究 Research on process simulation	前处理、钝化工工艺模拟装置 Preprocessing and passivation process simulator
37	钝化工工艺模拟 Simulation of passivation process		自动排出型烘烤炉 Automatic discharge oven	
38	食品安全及工艺介质研究 Research on food safety and technology medium	介质成分分析 Analysis of medium composition	ICP 光谱仪 ICP spectrometer	
39		介质成分分析 Analysis of medium composition	紫外可见分光光度计 UV spectrophotometer	
40		介质成分分析 Analysis of medium composition	自动电位滴定仪 Automatic Potentiometric Titrator	
41		介质阴离子成分分析 Analysis of medium anionic composition	离子色谱 Ion chromatographyn	
42		介质有机成分分析 Analysis of organic components in medium	高效液相色谱 High performance liquid chromatography	
43		消解制样 Digestion and sample preparation	微波化学工作站 Microwave chemical workstation	
44		镀液、成品铅含量分析 Analysis of lead content in bath and finished product	原子吸收光谱仪 Atomic Absorption Spectrometer	
45		微观表面 Microsurface	微观形貌和组分 Micromorphology and composition	扫描电子显微镜 Scanning electron microscope
46	表面三维轮廓 Surface 3D contour		光电轮廓仪 Optical profilometer	
47	表面色差研究 Study of surface chromatic aberration		光泽度仪 Vancometer	
48	微观形貌快速分析 Rapid analysis of micromorphology		USB 显微镜 USB microscope	
49	微观形貌快速分析 Rapid analysis of micromorphology		PEAK 必佳放大镜 PEAK Bija Magnifier	
50	罐盖性能 Performance of can body and ends	罐、盖耐压强度 Pressure strength of tank and ends	三片罐耐压强度检测仪 Pressure no return for cans	
51			盖子耐压强度测定仪 Pressure no return for ends	
52			轴向承压测试仪 Axial load test	
53			拱底耐压跟踪仪 Arch bottom pressure tracker	
54		罐真空度 Vacuum degree	空罐试漏仪 Air tank leak tester	
55		封罐 Sealing	自动封罐机 Automatic sealing machine	
56		封罐 Sealing	二重卷封检测仪 Double sealing tester	



ATC 装置
ATC device



皇冠制盖
Crown cap forming machine



起棱试验机
Prism test machine



制耳冲床
Earing simulation



X 荧光光谱仪
Xfluorescent spectrometer



镀锡板多功能检测仪
Multifunction measuring instrument for tinplate



自动排出式烘箱
Automatic discharge oven



焊机
Three-piece can welder

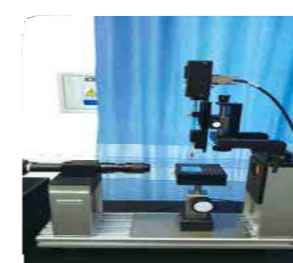

接触角
Optical Contact Angle tester



光电轮廓仪
Optical profilometer



椭圆仪
Ellipsometer



拉伸机
Tensile testing device

Chapter 4 Product Service System

第四章 服务体系

首钢京唐秉承以用户为中心的经营理念，全面深化与用户的战略协作。在新品研发、材料选用、资源配置、拓展合作渠道等方面进行深层次合作。

Upholding the user-centered operation philosophy, Shougang Jingtang deepens strategic cooperation with users in an allround way through carrying out deep-level cooperation in such aspects as new product research & development, material selection, resource configuration and expansion of cooperation channels.

售前服务 Pre-sale service	
■ 提供详细的镀锡板介绍材料与标准	■ Providing detailed instruction data and standards of tinplate.
■ 为用户提供正确的选材指导	■ Serving users with instructions on correct selection of material.
售中服务 In-sale service	
■ 合同跟踪	■ Contracts tracking
■ 提供详细的用户合同跟踪信息，确保交货期	■ Providing detailed user order tracking information to ensure punctual goods delivery.
售后服务 After-sale service	
■ 质保书查询	■ 为用户提供质保书
■ Query for certificate	Providing users inspection certificate.
■ 技术支持	■ 为用户提供首产品在使用中各类问题的咨询以及使用现场跟踪服务
■ Technical supports	Providing users with advisories for various problems met during the application of Shougang Jingtang's tinplate products.
	■ 快速有效的处理产品质量异议，包括现场的跟踪调整试验，提供异议材料紧急替代方案，满足用户生产需求
■ 异议处理	Quickly and effectively handling claims on product quality, including site tracking & adjustment tests, provision of emergent substitute proposal against claimed materials to meet users' production demands.
■ Claim handing	■ 通过各种渠道收集客户信息，整理分类，改进产品，反馈用户，满足用户需求
	Collecting customers' information through various means, sorting and classifying the information, improving products accordingly, feeding back information to users and satisfying users' requirements.
■ 客户信息反馈	
■ Customer information feedback	

Chapter 5 Packaging and Marking

第五章 产品包装

5.1 钢卷、钢板的包装方式 Packing mode for coil and sheet

表 1 电镀锡钢卷的包装方式 table 1 Packing mode for electrolytically tined coils

序号 No.	包装代码 Packaging code	防锈纸 Antirust paper	塑料膜 Plastic film		内周护板 Inner protective plate			外周护板 Outer shield plate		
			普通 Ordinary	复合 Compound material	纸 Paper	纤维 Fibre board	钢 Steel	纸 Paper	纤维 Fibre board	钢 Steel
1	CT01	√					√			√
2	CT02	√	√				√			√
3	CT03	√	√		√		√	√		√
4	CT05	√	√		√		√	√		√
5	CT06	√					√			√
6	CT07	√	√				√			√
7	CT08	√	√		√		√	√		√
8	CT10	√	√		√		√	√		√
9	CT11	√	√					√		√
10	CT12	√	√						√	√
11	纤维板包装 Fiberboard package			√	√		√		√	√
12	钢托架包装 Steel bracket packing	√	√					√		

表 1 电镀锡钢卷的包装方式 table 1 Packing mode for electrolytically tined coils

序号 No.	包装代码 Packaging code	端护板 Side protective plate				护角 Angle protection		钢捆带 Banding strip	托架 Bracket	圆盒盖 Round cover	推荐方式图示 Illustration for recommend solution
		纸 Paper	塑料 Plastic	纤维 Fibre board	钢 Steel	纸 Paper	钢 Steel				
1	CT01		√			√	√	√			
2	CT02		√			√	√	√			
3	CT03		√			√	√	√			6.2
4	CT05	√			√	√	√	√			
5	CT06		√			√	√	√	√		
6	CT07		√			√	√	√	√		
7	CT08		√			√	√	√	√		6.3
8	CT10	√			√	√	√	√	√		
9	CT11	√			√	√	√	√	√	√	
10	CT12	√		√		√	√	√	√	√	6.4
11	纤维板包装 Fiberboard package			√		√	√	√			
12	钢托架包装 Steel bracket packing	√			√	√	√	√	√	√	

a 为硬纸护板，其它纸护板一般为瓦楞纸。Paper guards, others are normally corrugated paper. b 出口专用熏蒸木托架。Special fumigated wooden bracket for export
c 钢护板搭接处粘贴布基胶带。Duct tape is applied on the overlap of steel protective sheet

表 2 镀锡钢板的包装方式 Table 2 Packging mode for tined sheet

序号 No.	包装代码 Packaging code	防锈纸 Antirust paper	端护板 Side protective plate			侧护板 Side plate		下垫板 Bottom cover		钢护角 Steel corner guard	托架 Bracket	钢捆带 Steel banding strip	推荐图示 Recomend -Illustrati	捆包重量 Bundles weight
			钢 Steel	缓冲材料 Buffer material	盒盖 Steel package box	硬纸板 Cardboard paper	钢 Steel	钢 Steel	缓冲材料 Buffer material					
7	CT13	√	√	√ b	√		√	√	√ b	√	√木质 wood	√		≤ 2.1 吨 ton
8	CT15	√	√	√ b	√	√	√	√	√ b	√	√木质 wood	√	6.5	
9	CT16	√	√	√ c				√ c	√	√木质 wood	√			

b 一般为硬纸板。Cardboard generally;
c 一般为纤维板。Fiberboard generally;
d 出口专用熏蒸木托架。Outlet special fumigated wooden bracket.

首钢京唐镀锡板包装优点:

首钢京唐镀锡板包装特点 Packing Characteristics of Shou Steel for tin plate	密封性好 Good sealing
	满足用户的个性化需求 Meet customers' diversified requirement
	可回收，绿色、环保 Recycled, green, environmental protection



5.2 卧卷包装 (不带木托架) Horizontal form coil packing (Without wood bracket)

名称 Name	代码 Code	包装方式 Packaging mode	推荐使用范围 Recommended use Range
普通包装方式三 Horizontal form coil General packaging Three	CT03	<ol style="list-style-type: none"> 1. 钢卷; 2. 内芯纸板; 3. 防锈包装纸全封闭包装; 4. 普通工业膜全封闭包装; 5. 内周瓦楞纸护板; 6. 外周 2mm 厚硬纸板; 7. 端部瓦楞纸护板; 8. 内纸护角; 9. 外纸护角; 10. 内钢护板; 11. 外钢护板; 12. 端部塑料护板; 13. 内钢护角; 14. 外钢护角; 15. 钢捆带。 	<p>国内南方地区 火车运输 船运</p> <p>Southern China Train transportation Shipping</p>

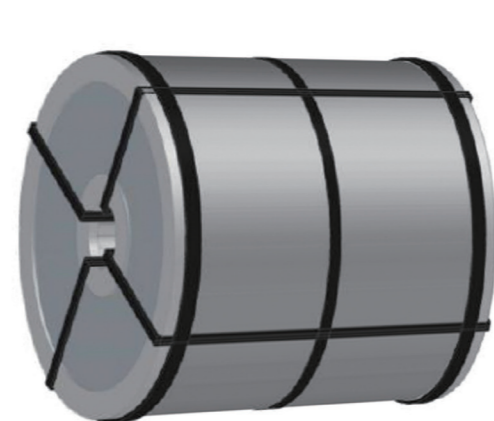

三维视图 Three-dimensional view

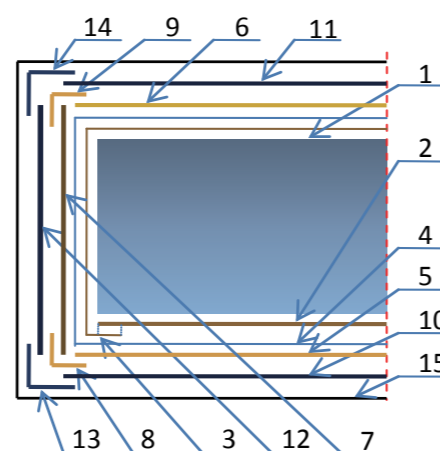

剖面视图 View profile

5.3 卧卷包装 (带木托架) Horizontal form coil packing (with wooden bracket)

名称 Name	代码 Code	包装方式 Packaging mode	推荐使用范围 Recommended use Range
普通包装方式八 Horizontal form coil General packaging Eight	CT08	<ol style="list-style-type: none"> 1. 钢卷; 2. 内芯纸板; 3. 防锈包装纸全封闭包装; 4. 普通工业膜全封闭包装; 5. 内周瓦楞纸护板; 6. 外周 2mm 厚硬纸板; 7. 端部瓦楞纸护板; 8. 内纸护角; 9. 外纸护角; 10. 内钢护板; 11. 外钢护板; 12. 端部塑料护板; 13. 内钢护角; 14. 外钢护角; 15. 钢捆带; 16. 木托架。 	<p>国内南方地区 火车运输 船运</p> <p>Southern China Train transportation Shipping</p>

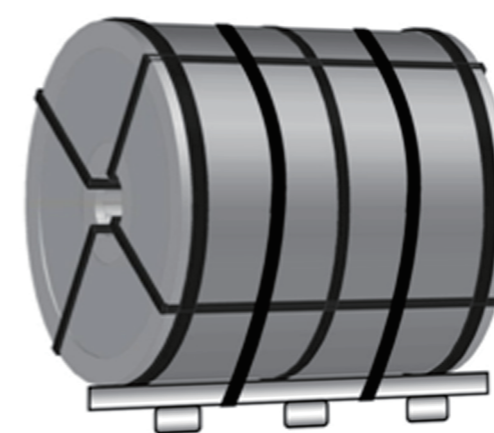

三维视图 Three-dimensional view

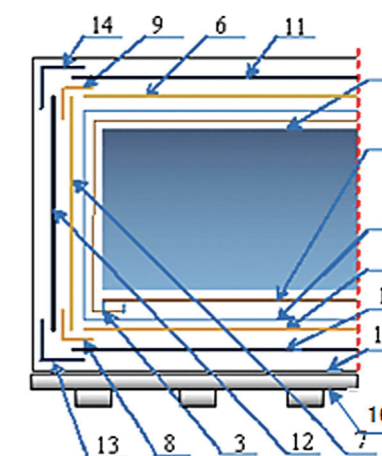

剖面视图 View profile

5.4 立卷包装 Hole vertical packaging

名称 Name	代码 Code	包装方式 Packaging mode	推荐使用范围 Recommended use Range
立式包装方式二 Vertical form coil Packaging	CT12	1. 钢卷; 2. 内芯纸板; 3. 防锈包装纸全封闭包装; 4. 复合工业膜全封闭; 5. 端部瓦楞纸护板; 6. 外周纤维维护板; 7. 端部纤维维护板; 8. 内、外纸护角; 9. 内钢护角; 10. 外周钢护板; 11. 圆盒盖; 12. 外钢护角; 13. 十字捆带; 14. 周向捆带; 15. 立式木托架。 1.steel coil; 2.cardboard core; 3.rest-proof paper wrapping closed wrapping plate; packaging; 4.industry Composite film closed packaging; 5.ends peripheral corrugated paper 6.external peripheral Fiber guard plate; 7.ends fiber guard plate; 8. paper inner and external corner guard; 9.steel inner corner guard; 10. external peripheral steel 11. round cover; 12. steel external corner guard; 13. cross banding 14. radial banding strip; round cover; 15. wood bracket .	出口 海运 长途运输 Export Shipping Long distance transport

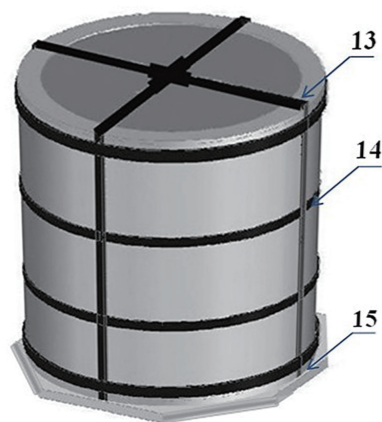

三维视图 Three-dimensional view

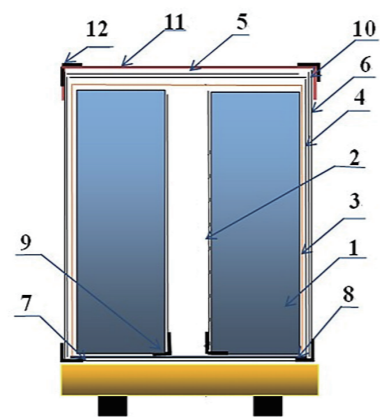

剖面视图 View profile

5.5 盒板包装 Box packaging

名称 Name	代码 Code	包装方式 Packaging mode	推荐使用范围 Recommended use Range
精包装方式一 Fine box packaging one	CT15	1. 木托架; 2. 下盖板; 3. 钢板; 4. 上盖板; 5. 底部硬纸板; 6. 防锈纸全封闭包装; (接缝处用胶带搭接) 7. 上部硬纸板; 8. 边部护角、上部护角、下部护角; 9. 周向、横向、纵向塑料捆带 (内) 10. 围板; 11. 盒盖; 12. 周向、横向、纵向钢捆带 (外)。 1.wood bracket; 2.bottom cover; 3.steel sheet; 4.top cover; 5.bottom cardboard paper; 6.rest-proof paper wrapping closed packaging; (Overlapping seams with tape) 7.top cardboard paper ; 8.side corner guard,top corner guard, bottom corner guard 9.(internal) plastic bands in circumfential, cross and longitudinal direction; 10.grard plate; 11.steel package box; 12.circumferential banding strip, horizontal banding strip, vertical banding strip (outer).	出口 海运 长途运输 Export Shipping Long distance transport

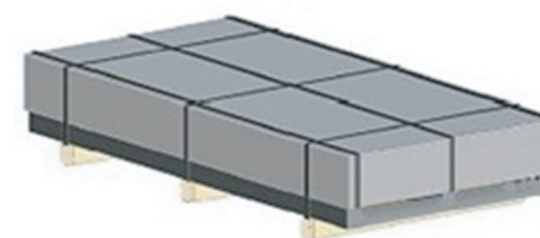

三维视图 Three-dimensional view

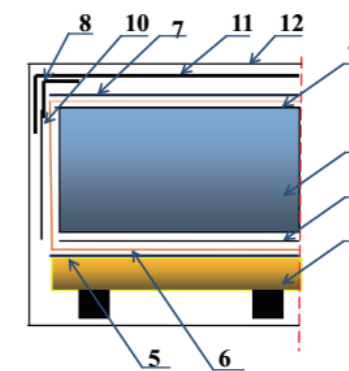

剖面视图 View profile

注:

可提供钢卷和钢板产品，钢卷提供立式和卧式包装形式。附有产品外标签和内标标签。
您需要的包装形式和标签要求，请联系我们确认。

Note:

Offers coils and sheets, coil packed in a vertical form or a horizontal.
A label that indicates the manufacturing history is affixed to the outside of the packaging. In addition, a service card is contained inside. With regard to types of packing and markings, please consult us.

Chapter 6 Ordering Guide

第六章 订购指南

订货时用户请注明下列信息

Please specify the following information when placing an order with products:

项次 ITEM	项目 INFORMATION	范例 EXAMPLE
1	产品标准号 Product standard	Q_SGZGS_0350-2019
2	牌号 Grade	MRT-4 CA
3	尺寸及其精度 (包括厚度、宽度、剪切长度) (mm) Specification and precision (Including thickness, width and cutted length)	0.20*858*1035
4	镀层重量 (g/m ²) Coating weight	2.8/2.8(25#/25#)
5	表面结构 (B、R、S、M) Surface finish	R
6	单卷重 (最大与最小) (吨) Minimum & maximum coil weight (metric ton)	6~13
7	成型方式 Way of Shaing	焊接 / 冲压 Welding/Punching
8	用途 (内容物) Application (contents)	饮料罐身 Beverage can body
9	订购数量 (吨) Order volume (metricton)	500
10	包装方式 Packaging	盒板包装 Box packaging
11	特殊要求 Special requirement	





首钢智慧供应链平台
Shougang for WeChat



扫描下载本册内容
Scan QR code to download this file

北京首钢股份有限公司
Beijing Shougang Co.,Ltd.



本手册以环保纸印刷
Using the recyclable paper

SGGF 2021-10-15-014



9 787203 118411